

Series 5000 Single Row Pole Top with SolarMount® Rails

Installation Manual 501.5

U.S. Des. Patent No. D496,248S. Other patents pending.

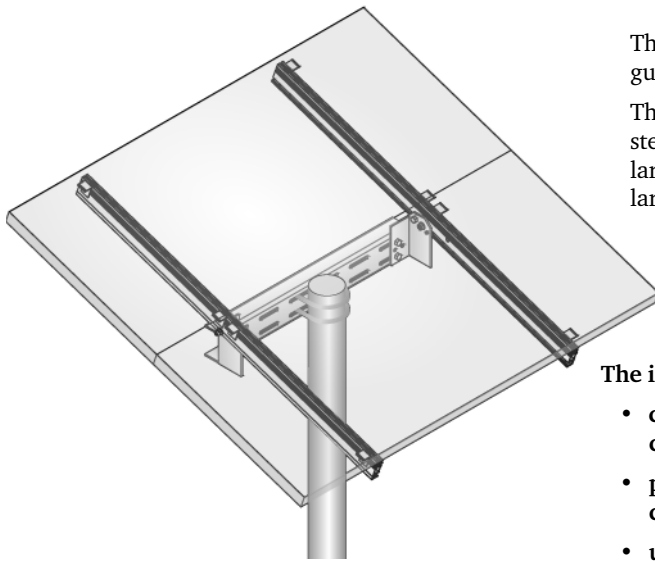

Thank you for purchasing a Unirac. Please read these guidelines completely before proceeding.

This rack is intended for a 2.5-inch (65 mm) Schedule 40 steel pole, outside diameter 2.875 inches (73.0 mm). For larger diameter poles, Unirac can fill special orders for larger U-bolts.

The installer is solely responsible for:



- complying with all applicable building codes, including any that supercede these instructions;
- pole installation appropriate to local wind and soil conditions;
- using only Unirac parts and installer-supplied parts as specified by Unirac (substitution of parts will void the warranty);
- installing all electrical aspects of the PV array.

Parts List (Parts are illustrated in exploded views, pp. 2–4.)

Part	Qty	Wrench size
Channel	1	
Bracket, left	1	
Bracket, right	1	
SolarMount standard rail, drilled	2	
U-bolt, 3/8"	2	
Hex head bolt, 3/8"	8	3/16"
Flange nut, 3/8"	4	3/16"
Self tapping screw, no. 10 zinc	2	
Module clip	4*	
Module bolt, 1/4"	4*	7/16"
Flat washer, 1/4"	4*	
Flange nut, 1/4"	4*	7/16"



Stainless steel hardware can seize up, a process called galling. To significantly reduce its likelihood, (1) apply lubricant to bolts, preferably an anti-seize lubricant, available at auto parts stores, (2) shade hardware prior to installation, and (3) avoid spinning on nuts at high speed. See Installation Supplement 910, *Galling and Its Prevention*, at www.Unirac.com.

* Per module to be mounted. Series 5000 racks include module hardware to mount 1 or 2 modules, depending on the model number.



See www.unirac.com for your nearest Unirac distributor.

Unirac welcomes input concerning the accuracy and user-friendliness of this publication. Please write to publications@unirac.com.

Pub 090616-6ii
June 2009

© 2009 by Unirac, Inc.
All rights reserved.

Mounting pole guidelines for Unirac PV PoleTops



The installer is solely responsible for use of these general guidelines. The following variances can affect your installation:

- The required diameter and depth of the hole depend on soil type. Sandy soil, for example, requires more concrete.
- The diameter and depth of the hole should also be increased wherever wind speeds exceed those listed in the table below, particularly if the site is open and unprotected. **Note the wind loading and exposure assumptions in the table note below.**
- Poles taller than 6 feet (1.8 metres) require that the depth of the hole be increased.

If in doubt, consult a professional civil engineer who is familiar with local soil conditions and wind loading requirements.

1. Dig the hole at least 4 inches (10 cm) deeper than required under “In-ground pole depth” in the table below. Fill the extra depth with gravel to allow water drainage.
2. Take some measure to prevent the pole from turning in the concrete during high winds.
3. Brace the pole so that it is plumb in the hole. Pour concrete around it, filling the hole to ground level. Add an inch or two (3 to 5 cm) of extra concrete above the hole. Trowel the concrete so that it slopes up to the pole (see table illustration).
3. Allow the concrete to set up for at least 24 hours before installing your PV Poletop.

Mounting Pole Requirements

Imperial				
Total module area	Design wind speed	Hole diameter	In-ground pole depth	Concrete volume
10 sq. ft.	90 mph	12 in.	30 in	2 cu. ft.
10 sq. ft.	120 mph	15 in.	40 in	4 cu. ft.
15 sq. ft.	90 mph	15 in.	40 in	4 cu. ft.
15 sq. ft.	120 mph	18 in.	42 in	6 cu. ft.

Metric				
Total module area	Design wind speed	Hole diameter	In-ground pole depth	Concrete volume
1 sq. m	150 km/h	30 cm	85 cm	0.06 m ³
1 sq. m	200 km/h	40 cm	90 cm	0.11 m ³
1.5 sq. m	150 km/h	40 cm	85 cm	0.10 m ³
1.5 sq. m	200 km/h	40 cm	135 cm	0.17 m ³

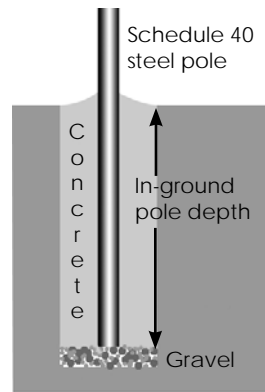

Assumptions: The pole extends no more than 6 feet (1.8 metres) above ground. Design wind speeds assume 29 psf wind force at 90 mph (150 km/h) and 51 psf wind force at 120 mph (200 km/h), which correspond to Exposure Category C of the International Building Code, terrain that is flat and generally open extending one-half mile (800 meters) or more from the site in any quadrant.

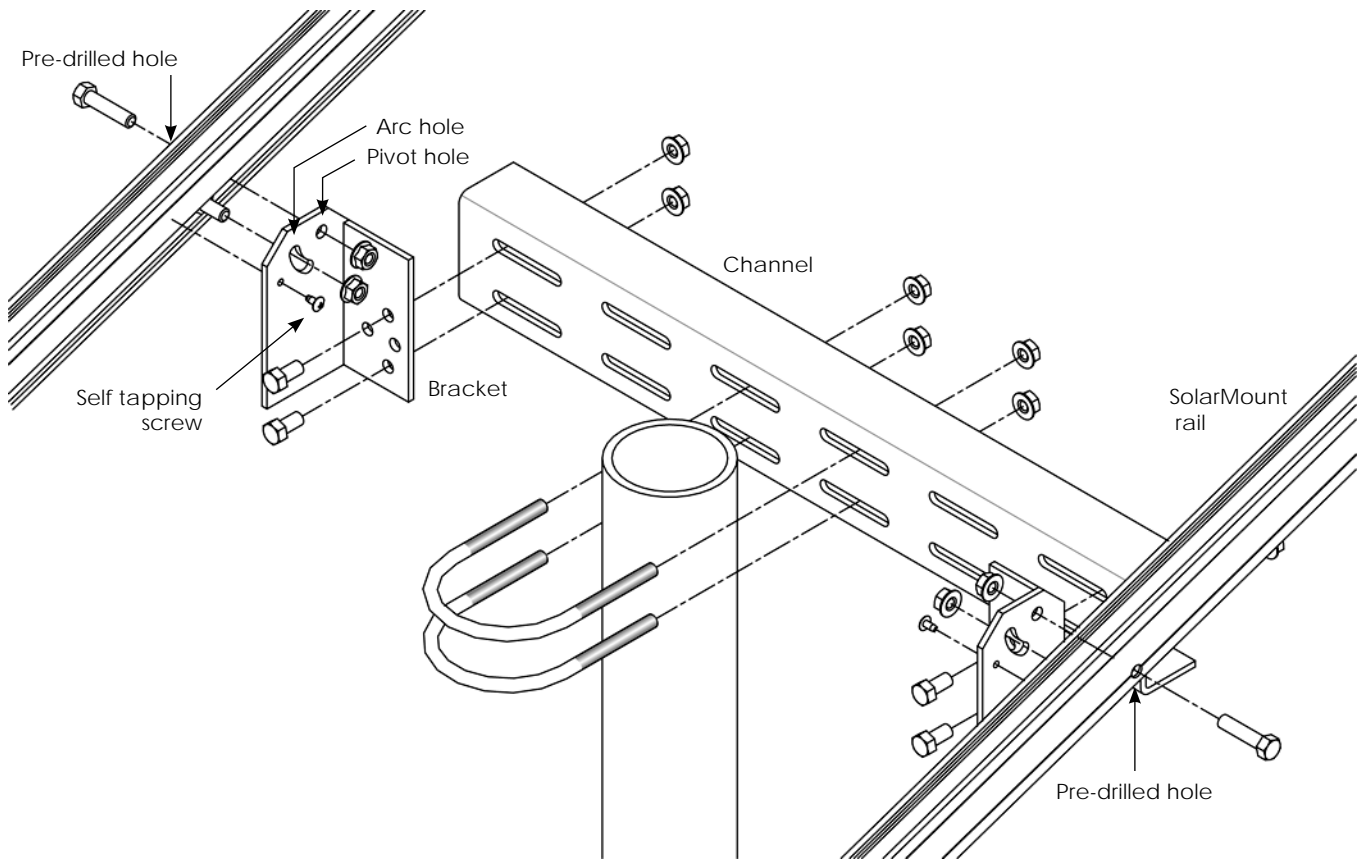



Assembly

Assembly order is not critical—except for installation of the self-tapping screws, which occurs last. You may work either from the pole outward, or you may complete the rack/PV module assembly before mounting it to the pole.

Loosely assemble all components.

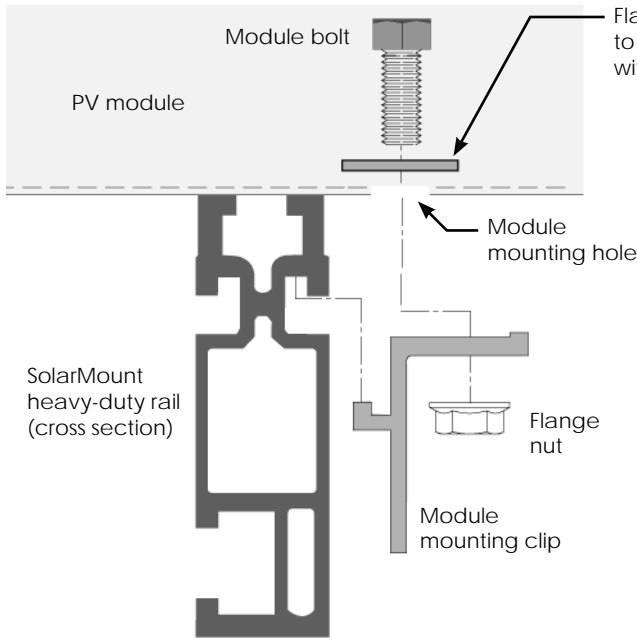
Be certain that the channel is centered on the pole and that brackets sit with the pivot hole above the arc hole.



Flat Washer: Most PV modules have mounting holes small enough to secure the module bolt without the washer. Use the washer with larger holes. If in doubt, use the washer. 

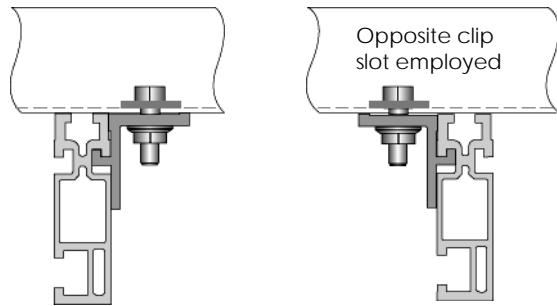

Module attachment

Attach the PV module to the rack using clips and 1/4-inch hardware. Be sure to center the module on the channel. If channel slots do not allow correct spacing and centering: (1) move the clips to the other side of the rails, (2) reverse the brackets, or (3) move the rails to the other side of the brackets.

Final adjustments

Once the rack/PV module assembly is attached to the pole, raise and rotate the assembly as needed. **Never let the assembly slide down the pole.** Tighten the flange nuts on the U-bolt and channel bracket bolts. Then tilt the rails to bring the module to the desired angle. Tighten the bracket/rail and module.

If desired, install the self-tapping screws to permanently fix the angle of the rack/PV module assembly.

10 year limited Product Warranty

Unirac, Inc., warrants to the original purchaser ("Purchaser") of product(s) that it manufactures ("Product") at the original installation site that the Product shall be free from defects in material and workmanship for a period of ten (10) years, from the earlier of 1) the date the installation of the Product is completed, or 2) 30 days after the purchase of the Product by the original Purchaser. This Warranty does not cover damage to the Product that occurs during its shipment, storage, or installation.

This Warranty shall be VOID if installation of the Product is not performed in accordance

with Unirac's written installation instructions, or if the Product has been modified, repaired, or reworked in a manner not previously authorized by Unirac IN WRITING, or if the Product is installed in an environment for which it was not designed. Unirac shall not be liable for consequential, contingent or incidental damages arising out of the use of the Product by the Purchaser under any circumstances.

If within the specified Warranty period the Product shall be reasonably proven to be defective, then Unirac shall repair or replace the defective Product, or any part thereof, in Unirac's

sole discretion. Such repair or replacement shall completely satisfy and discharge all of Unirac's liability with respect to this limited Warranty. Under no circumstances shall Unirac be liable for special, indirect or consequential damages arising out of or related to use by Purchaser of the Product.

Manufacturers of related items, such as PV modules and flashings, may provide written warranties of their own. Unirac's limited Warranty covers only its Product, and not any related items.